

# CDS 707: Retail

## How it is used

CDS 707 represents the perfect solution for retail back-offices. A small but smart, easy to use but high performing deposit unit, it is the right solution to meet any of your needs.

The extremely compact top plate is made of an input box which can hold up to 150 notes at a time with a simple and essential notes' transport, an authenticity sensor, a top cover customisable in colour and an exit box.

The 8 banknotes/sec input speed is ideal to manage high cash volumes. A user-friendly interface equipped with a PC board completes the work: the operator identifies themselves through the Dallas key or the card reader and follows the deposit on a colourful and reliable touch screen, and then prints their own receipt.

At the same time the online system banks the data. CIMA offers two kinds of bags: the high capacity canvas bag containing up to 10,000 notes and locked by a cover and a manual seal, and the self-sealing disposable bag containing up to 4,000 notes, whose safety is doubly guaranteed by a dual locking system.

The self-sealing bag, which is called "WinWin" bag, releases the safe's opening only once it has been completely sealed, thereby allowing its removal and money collection by one individual operator.

The operation can now be achieved by one person whilst maintaining the integrity and security with that of two people because there is no access to the bulk cash.

WinWin bags come with the RFID technology, which not only allows to store all data (unit that gave out the money, operator, banknotes' quantity), but most importantly it guarantees that no uncompliant or opened bags are used.

## Features

### Safe available in

8 mm, UL291 24 H, CEN III

### Weight

from 170kg to 410kg according to configuration

### Electrical characteristics

Voltage 90 – 240 V AC

Frequency 50 – 60 Hz

Power input 200 W

### Connections

RS232 serial port, or USB 1.0 port or ethernet

### Deposit capacity

Up to 10,000 banknotes with the canvas bag

Up to 4,000 banknotes with the self-sealing bag

### Banknotes' sensor

Authenticity ECB certified

Possibility of multi-currency operation

### Deposit speed

Up to 8 banknotes/sec

### The interface includes

60 mm thermal printer

5.7" TFT Colour Touch screen

PC board

Hard disk

Dallas key

### Options

UPS

GPRS interface

Card reader

Additional bags

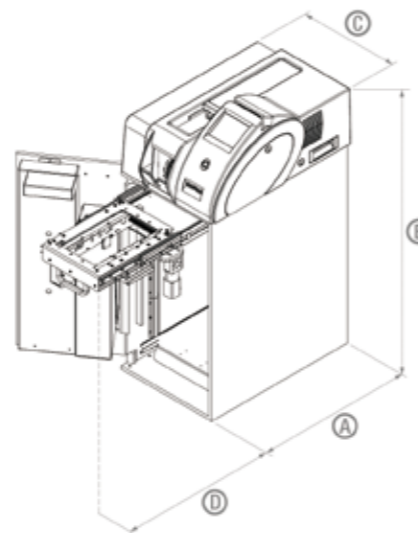

- (A) 600mm - UL291  
680mm - CEN III
- (B) 1042mm - UL291  
1100mm - CEN III
- (C) 400mm - UL291  
450mm - CEN III
- (D) 600mm - UL291  
600mm - CEN III

## Examples of applications

- Service Stations
- Gaming Venues
- Liquor Stores
- Supermarkets
- Newsagents
- Bus Depots
- Government Agencies (eg Licensing centres)

## Flow chart model

The flow chart below shows the suggested setup for any retail store:

